

Article Info

Received: 25 Jan 2021 | Revised Submission: 20 Apr 2021 | Accepted: 28 May 2021 | Available Online: 15 Jun 2021

Computational Investigation and Optimization of Cooling System used for Hub Motors

V. V. Gagan Swaroop*, Minesh Vohra**, Naga Sesha Reddy***, Venu Kondem****,
V. Subrahmanya Saidev***** and P. H. Sai Sumanth*****

ABSTRACT

The main aim of doing this project is to fix the strategy to provide the cooling for a hub motor so that there will be no effect on the copper windings of the motor while operating under variable load conditions. This work is carried out because of the fact that if the motor reaches the higher limits of its operating temperatures then the winding will get heated up and also there would be possibility of damage of the motor. So basically, we have proposed a fin attached casing from which the 30 numbers of fins are protrudes from the outer surface of hub motor and these fins are mounter in the open atmospheric condition considering the convectional heat transfer as low as possible based on the flow velocity of air and that is 5 W/m²K. Also, this value had been justified based on analytical approach followed in the study in order to find out the efficiency of the fins installed. We chose the casing material as stainless steel and fin material as aluminum because they have good thermal conductivity. The Computational investigation is carried out using ANSYS Module and the parameters i.e. Temperature distribution, Total heat flux and Directional heat flux were investigated based on the optimization technique followed based on two models that are a) Hub-Motor with Fin b) Hub-Motor without Fin. From the numerical investigation we achieved the Fin efficiency as 99%, followed by Heat dissipation from fin is 232.12 W and Fin effectiveness as 0.032 and hence results into an efficient model for the better cooling of the hub-motors of chosen dimension.

Keywords: Heat transfer; Hub motor cooling; Fin efficiency; Fin performance.

1.0 Introduction

The most popular type of electric bicycle motors is undoubtedly the hub motors, which position the electric motor in the middle of a wheel. These motors are available at very reasonable price and also have a less maintenance cost. There are different sizes of hub motor in the market which are used for different purposes. Efficiency also matters in this motor if a driver needs a higher efficiency motor then he should prefer a high watt hub motor. Also, the size of the

hub motor changes as the watts increases. Two distinct types of hub motors are available out of which the geared 500W motor is suitable for most riders.

2.0 Types

2.1 Geared motor

A compact and lightweight motor spins within this geared motor very easily. In order to minimize the rpm to the proper speed for a bike wheel, this

*Corresponding author; School of Mechanical Engineering, Lovely Professional University, Phagwara, Punjab, India (E-mail: gaganswaroop935@gmail.com)

**School of Mechanical Engineering, Lovely Professional University, Phagwara, Punjab, India (E-mail: mines.15783@lpu.co.in)

***School of Mechanical Engineering, Lovely Professional University, Phagwara, Punjab, India (E-mail: seshureddy1999@gmail.com)

****School of Mechanical Engineering, Lovely Professional University, Phagwara, Punjab, India (E-mail: venureddykondam@gmail.com)

*****School of Mechanical Engineering, Lovely Professional University, Phagwara, Punjab, India (E-mail: v.s.saidev1998@gmail.com)

*****School of Mechanical Engineering, Lovely Professional University, Phagwara, Punjab, India (E-mail: saisumanthpanga@gmail.com)

electric bike motor then uses a planetary reduction gear within the motor. High power and torque are therefore generated by a smaller motor that weighs less.

The geared motor also has an internal freewheel, so the motor does not get to spin unpowered while we travel even without motor on. This increases the coasting distance, and with the motor power off the engine does not add resistance to pedaling. A geared motor does not produce power by coasting because of the inner freewheel.

2.2 Direct-drive motor

The motor of this electric bike is a direct drive unit. This engine is normally about 1.8kg avg. Heavier than the sort of geared one. At the optimal rpm for motorcycles, a bigger motor with wider magnets turns. In a direct drive engine, there is only one moving part, so it is extremely difficult to sweat one out. For the toughest type of use the electric bike motor with direct drive is ideal.

Figure 1: Geared Motor (500 W)



Figure 2: Direct-Drive Motor



That normally means more weight, and the hills are very long. So, for twin bikes, cargo bikes, or riders that weigh more than 100kg, we have a direct drive engine. When you coast, there is a tiny bit of resistance generated by a direct drive engine. By operating the motor on a tiny trickle of power, this can be absolutely avoided.

This is where the 5 power level setups function well. You can pedal or coast with minimal drag, and virtually no power required, using the lowest power level, and a tiny bit of throttle. By using the motor minimally, it's perfect for stretching range. [1] In his research, Dong Hyun Lim et al. experimentally tested the heat dissipation output of a 35-kW-class large-capacity in-wheel motor fitted with a high cooling performance internal-circulation-type oil-cooling system that can easily be miniaturized to this motor and reported that the radiator cooling system demonstrated thermally stable operation. Furthermore, they claimed that cooling system with the radiator provided additional driving times of approximately 22 s and 2 s, respectively under maximum-rating base speed and maximum-rating maximum speed driving conditions. Fulai Guo et al. [2] has investigated the oil cooling aspects of Permanent Magnet Synchronous Motor and shows that Generally the regular motors have poor heat dissipation conditions because of their working space, environment and high temperature. Additionally, in the work they proposed improvement in the power density and torque density. The inner motor is considered as the research object for the end winding and stator core. The 3D model was designed by using ANSYS software and concluded that the oil-cooled technique has a strong cooling effect on the stator core and performs under rated conditions for a longer time.

Qiping Chen et al. [3] in the work carries a research based on the theory of electromagnetic field and working principle of motor. In addition, the size of the micro-electric vehicle wheel is calibrated and planned, and the length of the inner and outer diameters of the inner stator and the outer rotor are designed and measured for the in-wheel motor of the outer rotor. Jeff LaMarre et al. [4] worked on the design and installation of a powerful Electric Vehicle Formula SAE cooling system. A comprehensive heat flow study of the water side and air side of a possible radiator was conducted throughout the design phase and the radiator inlet duct was also developed to

guide air to the radiator and boost the device efficiency. Pan Bo et al. [5] In his analysis proposed an example of a 75-kW outer rotor hub motor and researched and examined the failure, heating and cooling of the hub motor for electric vehicles. The temperature distribution of each part of the hub motor under various cooling modes was determined and obtained on the basis of the model. The temperature rises curves of and part at various flow rates are obtained by adjusting the flow rate of cooling water, and the best cooling system is eventually chosen. Omkar Bhatkar et al. [6] in his research investigated the radiator configuration specifications for an FSAE racing car with an emphasis on increasing the performance of the engine and reducing the total radiation scale.

Chong Wang et al. [7] presents the design of an integrated ECU (Electronic Control Unit) cooling system controller for hybrid electric vehicles involves tests to check the efficiency of the ECU and to evaluate optimum strategies for fan speed control. The ECU design is stable and the 8 Journal of Electrical and Computer Engineering will save at least 15 percent. Tim Woolmer et al. [8] study a wheel-hub motor that contains a rotor with permanent magnets. The engine could be an axial flux machine, the coils being wound on bars spaced circumferentially along an Int. rotation axis. Rotor Cl. The vehicle wheel is mounted directly on the rotor housing of the HO2K9/20 (2006.01). Chengning ZHANG et al. [9] suggested that The Hub motor has weak conditions of heat dissipation restricted by the installation space and working environment, a bottleneck to further boost the power density and torque density was a high temperature increase in the operating phase. The engine prototype's low-speed high-torque, one-hour temperature rise test was performed on a laboratory-built bench, and the test results were compared with the simulation results of the temperature sector, showing a strong accuracy that confirmed the model's rationality.

Dong Hyun Lim et al. [10] developed and produced an improved model for in-wheel motors, fitted with an integrated oil spray cooling channel, and assessed their thermal efficiency under continuous rating conditions. The highest coil temperatures at the base and maximum velocities set as the design points were below the motor temperature limit of 138.1°C and 137.8 °C

respectively. Micah Toll et al. [11] patented a liquid-cooled electric bicycle motor design. Yannis L Karnavas[12] carried a work for a light permanent magnet synchronous motor (PMSM) with an in-wheel electric vehicle (EV) application, and created effective cooling unit. In this sense, various simulations were first carried out using the Finite Elements Method (FEM) for the determination of the distribution of temperatures in different areas of the machine under different operating conditions. Next by analyzing certain criteria, an analysis of the proposed cooling system efficiency was carried out., such as the coolant's inlet temperature and the corresponding flow rate. Based on these results the final specifications of the cooling system are determined. Finally, the cooling system's efficiency according to the motor's output power range is examined. Based on the literature review and keeping in view the integration of motors in the hub of Electric motor drives used on EVs, the study has been carried in order to investigate the performance of cooling system of hub motor, based on the heat dissipation model followed by transient analysis with the objective of the work as:

- To design a cooling system model for the easy heat dissipation from the Hub Motor.
- Analytical Study of proposed model with and without Fin followed by Numerical investigation of the following parameters:
 - a. Temperature Distribution
 - b. Heat Flux Variations
 - c. Directional Heat Flux

3.0 Computational Investigation

The major aspects for the computational approached followed in this study are as follows:

- Designing Using Design Modular in ANSYS
- Meshing and Face Allocations
- Model and Material Specifications
- Boundary Conditions
- Solution Initialization and Iteration

3.1 Model components: Model with FINs

- Inner Diameter: 100mm
- Outer diameter: 120mm
- Outer diameter with fins: 140mm
- Fins: 30
- Fin thickness: 1mm
- Fin height: 20mm

- Fin material: Aluminum
- (Thermal Conductivity=237.5 W/m K)
- Casing Material: Stainless Steel
- (Thermal Conductivity=13.8 W/m K)

Figure 3: 2d Model of Hub with Fin

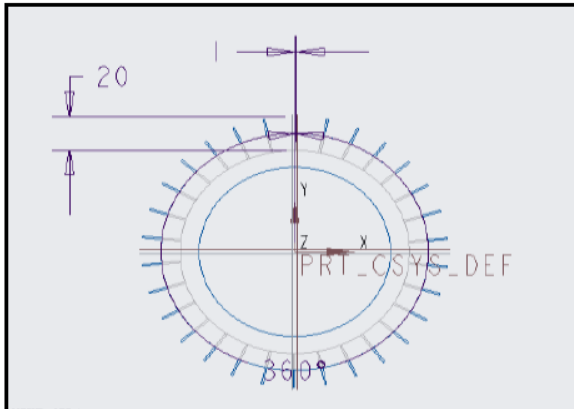

Figure 4: Isometric View

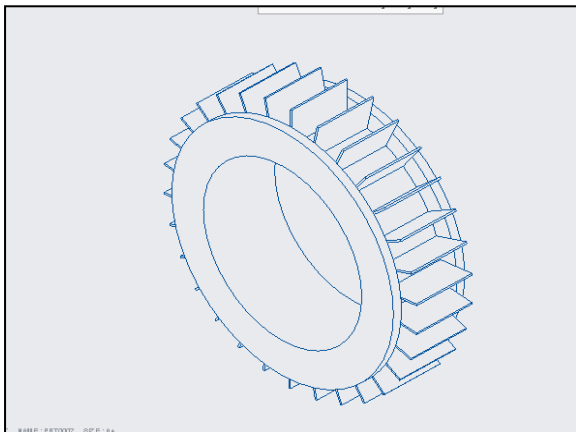

Figure 5: Fin Side View

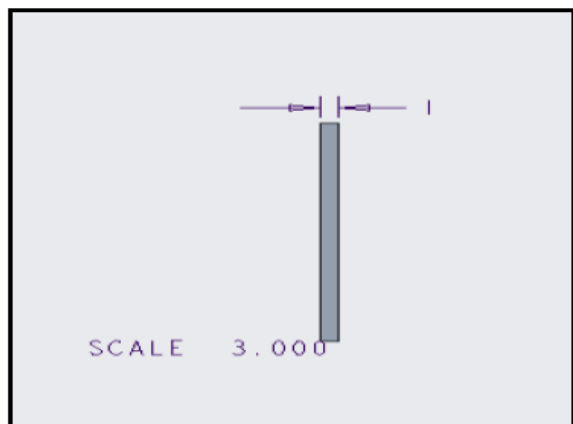

Figure 6: Top View

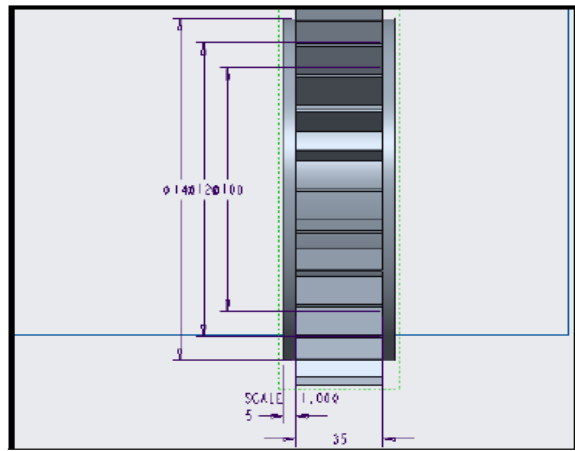

Figure 7: Front View of Fin

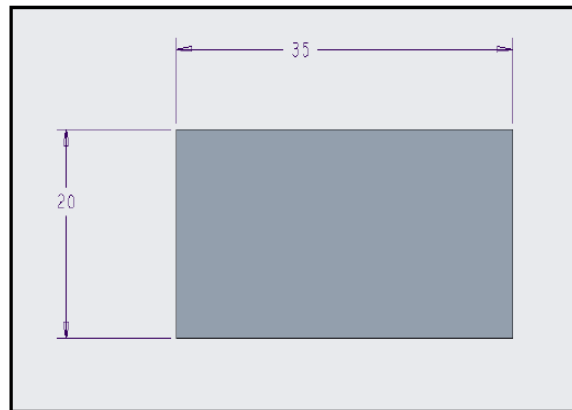
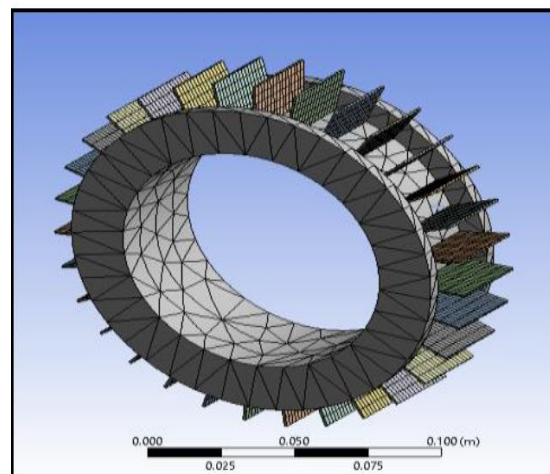

Figure 8: Meshed Model of Hub with Fins



On the isometric view of the geometry meshing is applied. With the help of meshing we can divide

the model into different parts and temperature can be set to them. By selecting the convection from the steady state thermal boundary conditions, the outline model is selected and atmospheric temperature is fixed to 22°C.

Figure 9: Convection Allocation Over the Surface of Hub

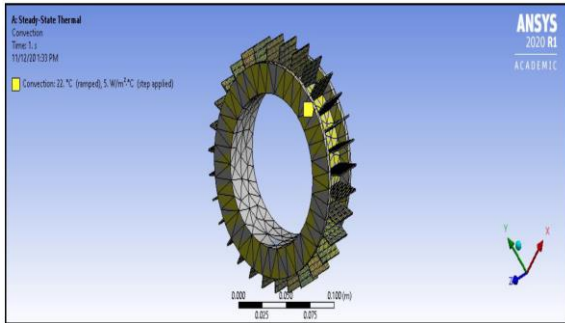
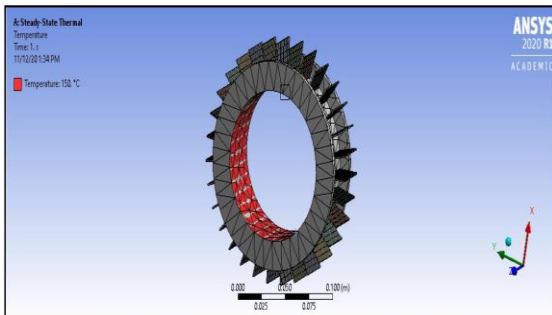

Figure 10: Temperature Across the Hub Surface (Outer Dia of Hub)



After the meshing the temperature boundary conditions were set to 150 °C on the inner part because the max heat which can be dissipated from the hub motor is 150 °C as per the operating condition of Motor operated Hub wheel

3.2 Without fins

- Inner Diameter: 100mm
- Outer diameter: 120mm
- Outer diameter with fins: 140mm
- Fins: 30
- Fin thickness: 1mm
- Fin height: 20mm
- Fin material: Aluminum
- (Thermal Conductivity=237.5 W/m K)
- Casing Material: Stainless Steel
- (Thermal Conductivity=13.8 W/m K)

Fig 11: Meshed Model without Fin

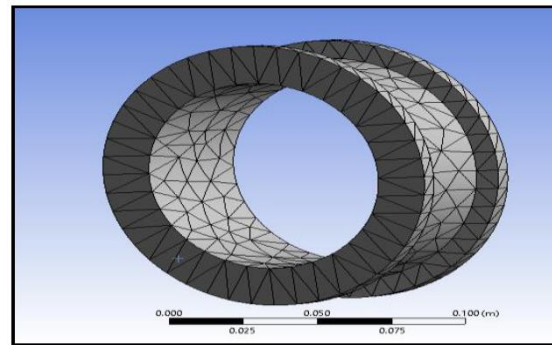

Figure 12: Convection Without Fins (Model)

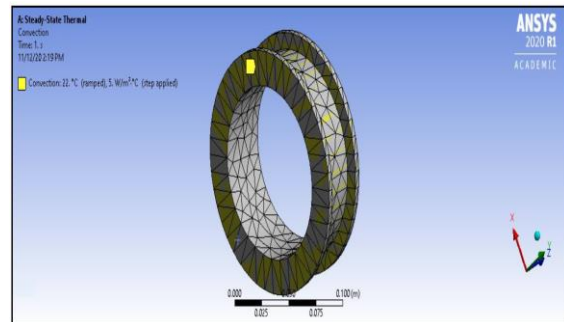
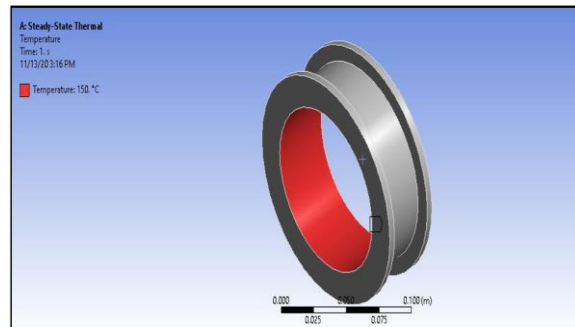

Figure 13: Temperature Across the Hub Surface (Outer Dia of Hub)



The temperature must be applied in the inner surface of the circular model by changing the magnitude temperature to 150 degrees. As the atmospheric temperature is applied in this case in order to kept this model based on convective heat transfer. And the film coefficient and Stagnant Air-Simplified Case has been considered for the final investigation based on heat transfer aspects.

4.0 Formulation and Calculation

Formulation and Calculation involved in this study is prescribed in this section which is as follows:

Considering $h=5W/m^2K$ specified based on the velocity of air, $T_S=150^{\circ}C$ is the temperature at the surface of hub without fin and T_o is $22^{\circ}C$ is the temperature of the atmospheric conditions that has been taken into account for calculations here A_s is the Surface area of the hub is calculated using $A_s=11.2 m^2$. P is a perimeter of fin which has been considered in the calculations and is calculated by using the relation-

$$P=2 \times (w+l) = 0.11 m \quad \dots(1)$$

Another thermophysical property k which reflect thermal conductivity of the fin material (Aluminum) and is considered to be $237.5 W/mK$. A_c is the cross-sectional area of the fin and is calculated using the equation-

$$A_c = 2 \cdot w \cdot L_c \quad \dots(2)$$

where $w=0.035m$ and $L_c=[L+(t/2)]$ and $A_c=1.435m^2$

4.1 Fin efficiency

$$\eta = \frac{\tanh h (mL_c)}{mL_c} \quad \dots(3)$$

Here,

$$mL_c = \sqrt{\frac{2h}{k \times \text{thickness of fin}}} \times L_c \quad \dots(4)$$

$$mL_c = 0.13$$

From above Equation (3) we get

$$\eta = \frac{\tanh h (0.13)}{0.13} = 0.99 \text{ or } 99\%$$

4.2 Rate of heat transfer from fin losing heat at Tip having finite length

$$Q_{fin} = \sqrt{h \times p \times k \times A_c (T_S - T_o)} \left[\frac{\tanh(mL_c) + \frac{h}{km}}{1 + \frac{h}{km}(mL_c)} \right] \quad \dots(5)$$

$$Q_{fin} = 232.12 W$$

4.2 Fin effectiveness ϵ : $\frac{\text{Heat transfer with Fin}}{\text{Heat Transfer without Fin}}$

$$\epsilon = \frac{Q_{fin}}{Q_{without Fin}} = \frac{Q_{fin}}{h \cdot A_s \cdot (T_S - T_o)} \quad \dots(6)$$

$$\epsilon = \frac{232.12}{5 \times 11.20 \times (128)} = 0.032 \text{ or } 3.2\%$$

5.0 Result and Discussion

Based on the numerical investigation of hub motor the following parameters has been investigated with comparison between Hub wheel with and without fin arrangement that are: Temperature Distribution over the surface, Total Heat Flux and Directional Heat Flux

5.1 Hub motor with fins Arrangement over the surface

5.1.1 Final temperature distribution contours

Figure 14: Temperature Distribution Over the Surface

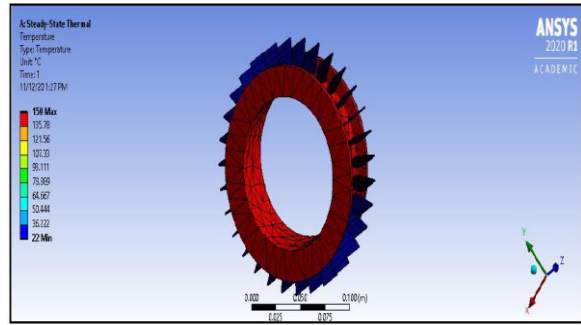

The red zone represents the heat dissipation and the blue represent the dissipation through fins and cooling the model.

5.1.2 Total heat flux contours

Figure 15: Heat Flux Distribution

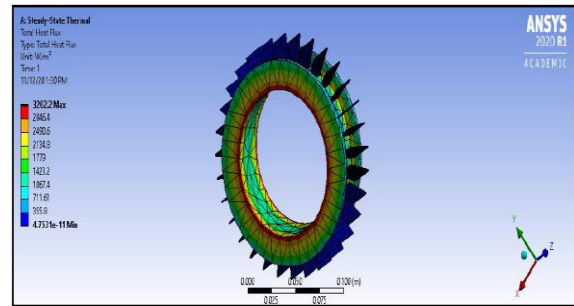

5.1.3 Directional heat flux Contours

Figure 16: Directional Heat Flux Distribution Over the Surface

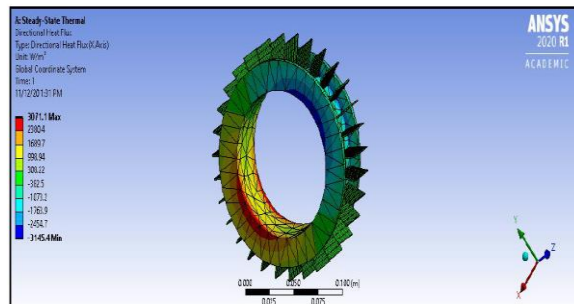

Table 1: Parameters Investigated for Hub Motor with Fins Arrangement Over the Surface

Sr. No.	Parameters	Minimum Value	Maximum Value	Average
1	Temperature	22°C	150°C	35.025°C
2	Total Heat Flux	4.7531e-11 W/m ²	3202.2 W/m ²	165.88 W/m ²
3	Directional Heat Flux	-3145.4 W/m ²	3071.1 W/m ²	0.15355 W/m ²

As per the simulated model it has been observed that the total heat flux varies from 3202.2 W/m² and the directional heat flux from 3071.1 W/m² to -3145.4 W/m².

5.2 Hub motor without fins arrangement over the surface

5.2.1 Final temperature distribution contours

Figure 17: Temperature Distribution Over the Surface (Without Fin)

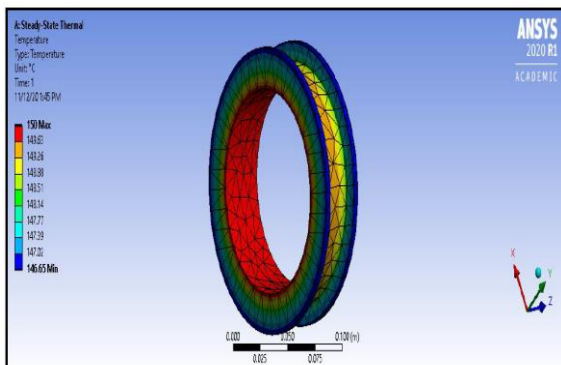

5.2.2 Total heat flux contours (without Fin)

Figure 18: Heat Flux Distribution (Without Fin)

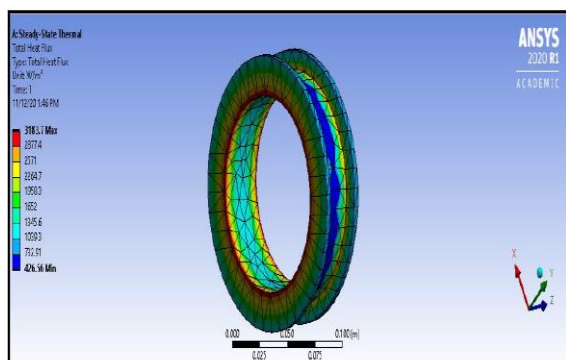

5.2.3 Directional heat flux Contours (without Fin)

Figure 19: Directional Heat Flux Distribution Over the Surface (Without Fin)

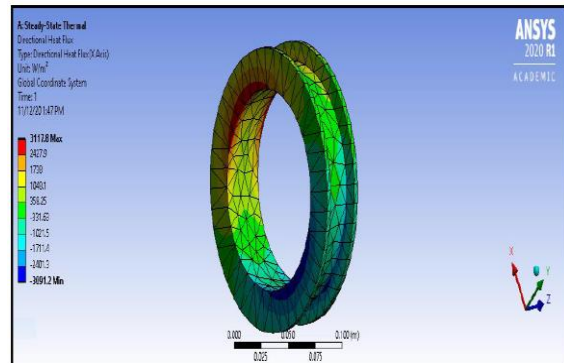

Table 2: Parameters Investigated for Hub Motor Without Fins Over the Surface

Sr. No.	Parameters	Minimum Value	Maximum Value	Average
1	Temperature	146.6°C	150°C	148.5°C
2	Total Heat Flux	426.56 W/m ²	3183.7 W/m ²	1646.7 W/m ²
3	Directional Heat Flux	-3091.2 W/m ²	3117.8 W/m ²	-6.7378 W/m ²

Result shows that there is a decrease in the maximum temperature value from 150°C to approximately 146.65°C over the surface and the total heat flux also increases from 3183.7 W/m² to 426.56 W/m² and with directional heat flux from 3117.8 W/m² to -3091.2 W/m².

5.0 Conclusion

The cooling is necessary in the hub motors because if the hub motor reaches its high temperatures the copper windings present inside the hub motor gets damaged or burned which lead to the damage of total hub motor. The model we made is by taking the gearless hub motor as our reference. The materials which we used are stainless steel and copper where fins were copper and the casing to which they were attached is stainless steel. If the hub motor reaches the highest temperature which is approx. of 150°C then the cooling model proposed here will provide promising response and the heat get dissipated outside through the fins and the hub motor starts the cooling process accordingly with the arrangement of the finds in much effective way.

This kind of cooling models in different hub motors and also can try positioning the fins in different orientation. Also not limited to this but yes, the optimization of the fin structure can be done in order to increase the heat capacity rate from the hub motors.

References

- [1] VVAlgat, RS Bhalerao, KN Autade, GB Shimpi, AP Godake. Hubless Wheel Bicycle with Gear Train Drive Mechanism, 3(2), 2015.
- [2] B Ross. Spoke-less bicycle system. 3(2), 2015.
- [3] F sbarro. Hubless cycle for engine driven vehicle, US07884322.
- [4] MR Mallaya, U Prasad. Design of Hubless Wheel for an Automobile, 6(2), 2016.
- [5] A Mothafar. Hubless wheel system for motor vehicles, US Patent 9440488B1, 2016.
- [6] NB Hung, J Sung. A simulation and experimental study of operating characteristics of an electric bicycle, 2017, 232-245
- [7] S Pinto, ER Kumar. Design and Analysis of Hubless Personal Vehicle, International Conference in advances in design and manufacturing, 2014
- [8] S Fuji. Crash Analysis of motorcycle tire, Procedia Engineering, 147, 200), 471-475.
- [9] IS Jacobs, CP Bean. Fine particles, thin films and exchange anisotropy, Magnetism, Schenectady, New York: Research Information Section, The knolls, General Electric. Research Laboratory. Technical Information Series, Report no. 63-RL-3224 M, 1963.
- [10] GT Rado, Hy Suhl, Eds. New York: Academic, 3, 1963, 271-350
- [11] GM Rosenblatt. The controlled motion of a bicycle, 2016, 221-228
- [12] PE Lew. Hubless wheel. US 5419619 A , 5, 1995.